

Inserting Battery

Step 1 Remove all packaging.

Step 2 Insert Battery 1/2AA ER14250 3.6v. As shown in Picture 7, positive facing out as per '+' sign on inside battery case.

Step 3 Secure battery with Battery Lid as per picture 8, click into position.

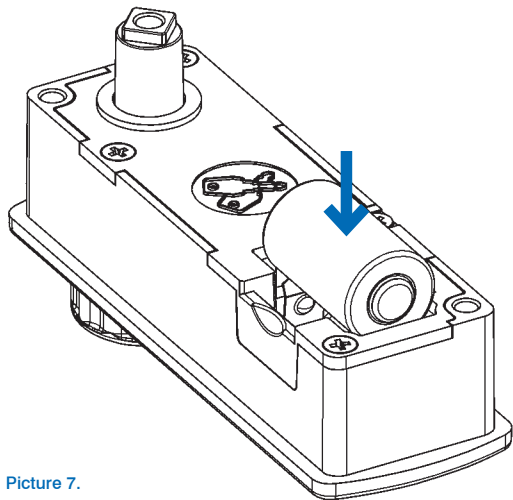

Picture 7.
Insert 1/2 AA Battery as shown.

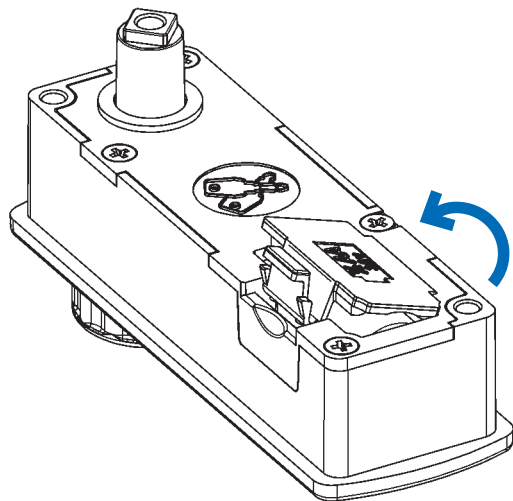

Picture 7.
Fit Battery Lid as shown click in place.

Important Note:

Before drilling fixing holes, please ensure that the position of the Digital Combination Lock when fitted will allow clearance for the cam to function.

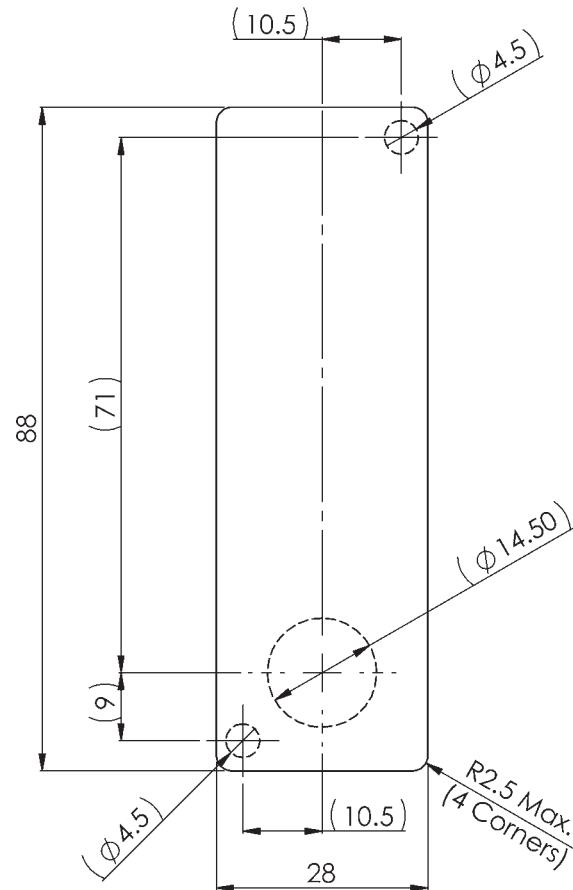

For flush fit option, use rectangular aperture (88mm x 28mm)
For surface mount option, use 3 x hole positions

**IF USING A PRINTED TEMPLATE ENSURE THAT THE
TEMPLATE IS THE CORRECT SIZE AS PRINTERS VARY**

Euro-Locks SA NV
Rue de la Fontaine 8
6600 Bastogne

T: +32 61 212.261
F: +32 61 212.265
E: sales@euro-locks.be
W: www.euro-locks.be

L&F A Lowe & Fletcher Group Company

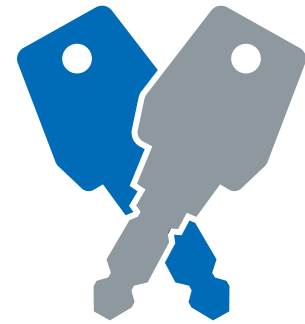

INSTALLATION INSTRUCTIONS

3700 - Gemini Digital

9224241 - GEMINI 'D' INSTALLATION INSTRUCTIONS - SEPT 2017

euro-locks.be

Gemini
combination and mechanical locks

INSTALLATION INSTRUCTIONS

3700 - Gemini Digital

Special Notes

Before installing the Digital Combination Lock, load the battery and familiarize yourself with the operation and programming. Unless manufactured to special order, the lock is supplied in the "PRIVATE" operating mode with a four-digit code. In this mode, the user must enter a four-digit User Code to open it. The unit will re-lock itself once open. The lock can be opened at any time using the Master Code.

Unless manufactured to special order, the default Master Code is 11 33 55 77 and the default User Code is 22 44. These codes are common to all standard locks and it is very important that you set your own personal Master and User Codes. Your lock is not secure until you have changed the default Master Code and User Code.

Keep a safe record of your master code as it is not possible to make any programming changes without it.

Please see programming guide to set your own codes.

The 3700 lock can be installed in two ways:

- Flush Mount (accessory kit 951600_)
- Surface Mount (accessory kit 951700_)

Surface Mount

Step 1 Remove all packaging.

Step 2 Fit the surface mount sleeve to lock as shown in Picture 1.

Step 3 Position the lock on the outside of the door as shown in Picture 2.

Step 4 Holding the lock in position, fit the 2 x M4 pan head screws (supplied with the surface mount sleeve) as shown in Picture 3.

Step 5 Tighten the 2 x M4 screws using a No.2 Posidriv® to 1Nm.

Step 6 Position the cam onto the rear of the lock as required, fit the cam washer and fixing screw as shown in Picture 6.

Step 7 Tighten the cam fixing screw using a No.2 Posidriv® to 1.5Nm. Take care not to damage the screw thread when fitting the screw.

Step 8 Before closing the door, test the lock by selecting the correct User Code and rotating 90°.

Step 9 Your lock should now be ready to use.

Flush Mount

Step 1 Remove all packaging.

Step 2 Position the lock on the outside of the door as shown in Picture 4.

Step 3 Holding the lock in position, fit the clamp box and 2 x M4 pan head screws (supplied with the clamp box) as shown in Picture 5.

Step 4 Tighten the 2 x M4 screws using a No.2 Posidriv® to 1Nm.

Step 5 Position the cam onto the rear of the lock as required, fit the cam washer and fixing screw as shown in Picture 6.

Step 6 Tighten the cam fixing screw using a No.2 Posidriv® to 1.5Nm. Take care not to damage the screw thread when fitting the screw.

Step 7 Before closing the door, test the lock by selecting the correct User Code and rotating 90°.

Step 8 Your lock should now be ready to use.

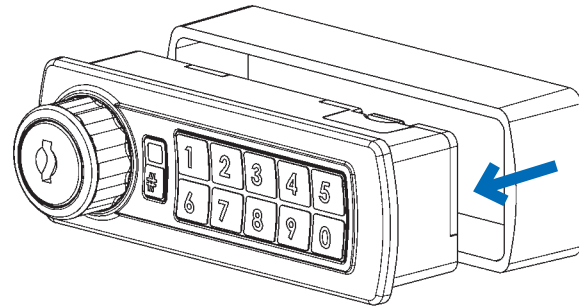

Picture 1.
Fit surface mount sleeve to lock as shown.

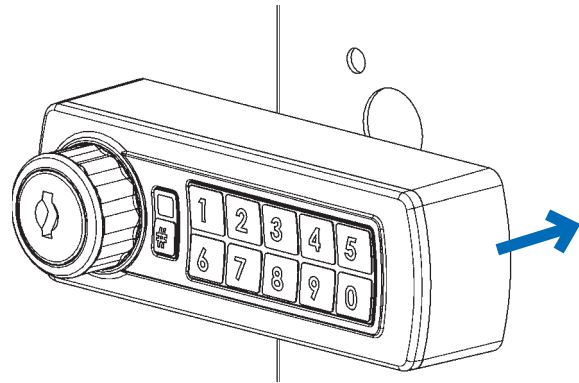

Picture 2.
Position lock on door panel as shown.

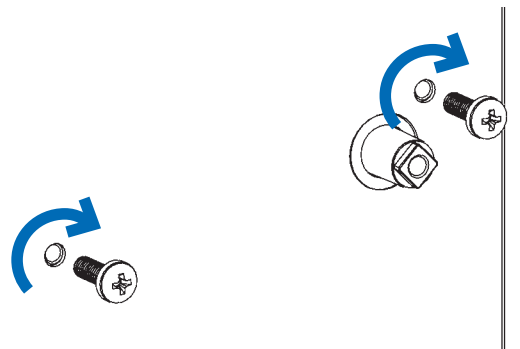

Picture 3.
Fit 2 x M4 pan head screws as shown.

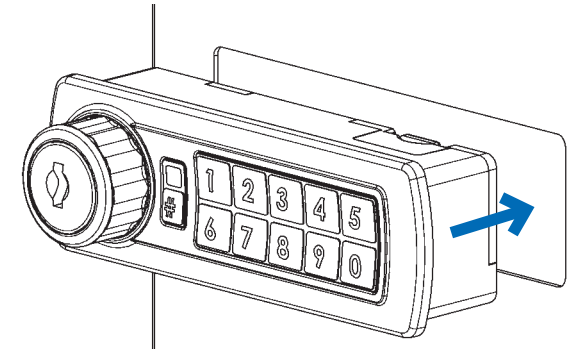

Picture 4.
Position lock through door panel as shown.

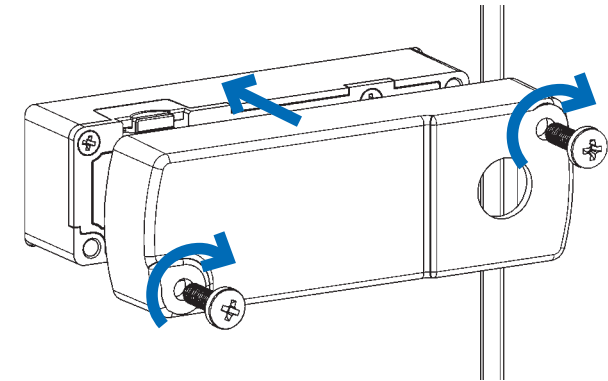

Picture 5.
Fit clamp box and 2 x M4 pan head screws as shown.

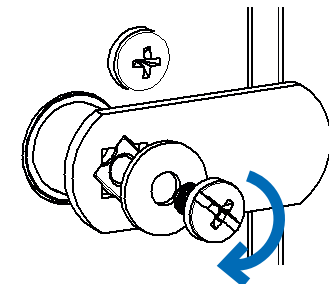

Picture 6.
Fit cam, washer & screw. Tighten with No.2 Posidriv®.